

Latches with push handle

Zinc alloy

HANDLE

Die-cast zinc alloy, provided with a hole for the insertion of a padlock with the hook of max diameter 9 mm.

FRONT BODY

Glass-fibre reinforced polyamide based (PA) technopolymer, black colour, matte finish.

SPINDLE AND PROTECTION CAP

Die-cast zinc alloy.

CLAMPING LEVER

Cylindrical element made out of die-cast zinc alloy, adjustable position by means of a hexagon socket grub screw, glass-fibre reinforced polyamide based (PA) technopolymer coating, black colour.

PACKING RING

Silicone strip applied to the base of the handle.

LOCK

With dustcover made out of acetal resin based (POM) technopolymer, red colour.

Two nickel-plated brass keys, removable in two positions at 90°.

IP PROTECTION

IP 65 protection class, IP65, see Table EN 60529 (a page).

STANDARD EXECUTIONS

Assembly by means of 4 zinc-plated steel screws co-moulded into the base and 4 zinc-plated steel nuts with thread lock included in the supply.

- **CSMH**: lock with 400 different combinations.
- **CSMH-U**: lock with one combination (all locks have a key with the same combination).

Index for handle colour:

- **BK**: black coated.
- **GR**: grey coated.



FEATURES AND APPLICATIONS

Close the door and move the lever to the closed position by rotating the handle by 90°. The overturning of the handle in its seat moves the spindle axially with the lever in the direction of the swing-door, until reaching the locking position.

The lock locks the handle in the folded position.

CSMH latches with compression handle guarantee a clamping range from 13 to 75 mm.

SPECIAL EXECUTION ON REQUEST

Executions with spindle of length 45 mm for range of latches from 13 to 43 mm.

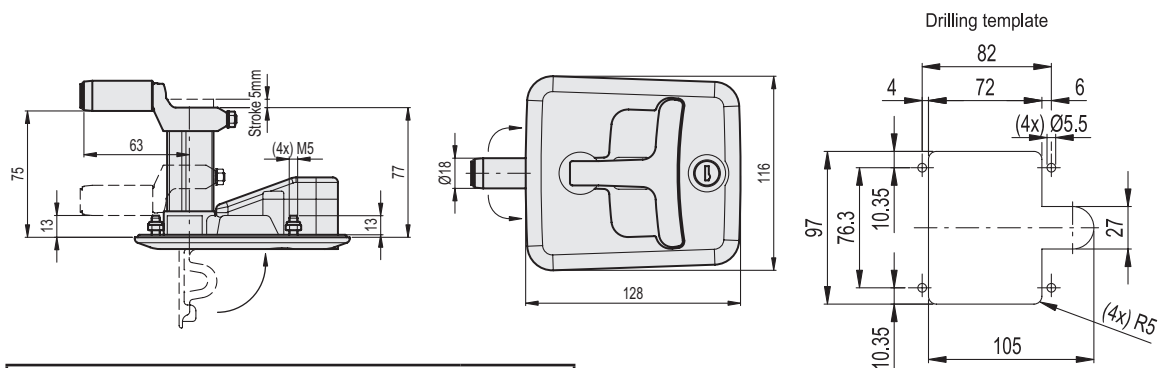

Code	Description	△
421501	CSMH-128-BK	507
421502	CSMH-128-GR	507
421503	CSMH-U-128-BK	507
421504	CSMH-U-128-GR	507